

INSTALLATION INSTRUCTIONS

Thank you for purchasing our product. Be sure to read the following installation instructions carefully before beginning installation. Make sure that the person in charge of system management stores this manual carefully for maintenance and management.

PHOTOELECTRIC DETECTOR

AX-350DH MK III maximum detection range: 350ft.(100m)

AX-650DH MK III maximum detection range: 650ft.(200m)

AX-350DH TS top/bottom unit AND/OR selectable
maximum detection range: 350ft.(100m)

AX-350DH BT model for beam tower, upper and lower unit AND/OR selectable
maximum detection range: 350ft.(100m)

FEATURES

- Digital communication function
- Cross talk prevention function
- Peak Finder Interface (P.F.I.) of Dual Alignment Level Indicator
- Mode-specific indicator allowing simple and accurate optical alignment
- Simple beam alignment without the "Beam Blocking Tool"
- Minimization of light disturbance
- ATPC (Auto Transmit Power Control) to optimize the power of beam
- Multiple beam installation of up to 4 sets
- Simple optical alignment
- High waterproofing property; jet-proof : IP65
- Wide optical alignment range:
 - ±90 degrees horizontally; ±20degrees vertically
 - *AX-350DH BT:
 - ±60 degrees horizontally; ±45 degrees vertically
- Reduced possibility of false alarms caused by flying objects

CONTENTS



1. INSTALLATION GOOD PRACTICE	2
2. PARTS IDENTIFICATION	3
3. NOTES ON INSTALLATION	3
4. INSTALLATION METHOD	4
5. TERMINAL CONNECTIONS	6
6. WIRING	7
7. OPTICAL ALIGNMENT	8
8. BEAM INTERRUPTION TIME ADJUSTMENT	11
9. RE-TRANSMISSION FUNCTION	11
10. WALK TEST	12
11. HEATER UNIT HU-2	12
12. BACK COVER BC-1	13
13. DIMENSIONS	13
14. TROUBLESHOOTING	15
15. SPECIFICATIONS	16

For Safe Use of the Product

☞ Read this instruction manual carefully prior to installation, for safe use of the product.









☞ After reading, store this manual carefully in an easily accessible place for reference.

☞ This manual uses the following warning indications for correct use of the product and preventing any harm to you or other people and damage to your assets, which are described below. Be sure to understand the description before reading the rest of this manual.

 WARNING	Failure to follow the instructions provided with this indication and improper handling may cause death or serious injury.
 CAUTION	Failure to follow the instructions provided with this indication and improper handling may cause injury and/or property damage.

 This symbol indicates prohibition. The specific prohibited action is provided in and/or around the figure.

 This symbol requires an action or gives an instruction.

 WARNING	Do not use the product for purposes other than the detection of moving objects such as people and vehicles. Do not use the product to activate a shutter, etc., which may cause an accident.	
	Do not touch the unit base or power terminals of the product with a wet hand (do not touch when the product is wet with rain, etc.). It may cause electric shock.	 
	Never attempt to disassemble or repair the product. It may cause fire or damage to the devices.	
	Do not exceed the voltage or current rating specified for any of the terminals during installation, doing so may cause fire or damage to the devices.	
 CAUTION	Do not pour water over the product with a bucket, hose, etc. The water may enter, which may cause damage to the devices.	
	Clean and check the product periodically for safe use. If any problem is found, do not attempt to use the product as it is and have the product repaired by a professional engineer or electrician.	

<Note> This product is not an antitheft device.

Please be notified that we will not be held responsible for any damage caused in the unlikely event of theft.

1. INSTALLATION GOOD PRACTICE

The following items are important to ensure the performance of the product. Be informed that the detector may not detect objects if not installed correctly.

[1] Mount unit only on a solid surface.

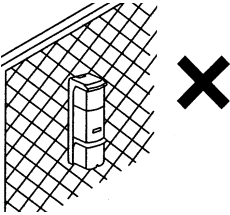

[2] Do not install the unit where objects moved by the wind such as plants and laundry, which may block the beam.

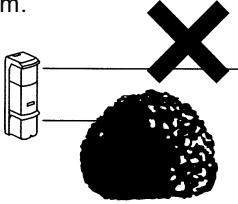

[3] Prevent direct sunlight from entering into internal optics.

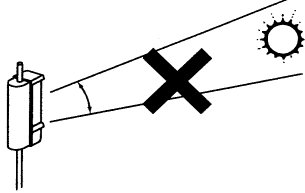

[4] Mount the units in such a way that the infrared beam of any other model does not enter the Receiver.

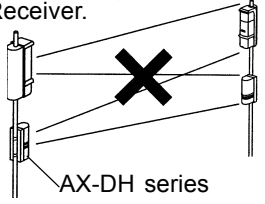

[5] Avoid aerial wiring.

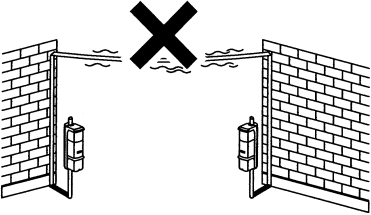

[6] The mounting pole should have a solid footing.

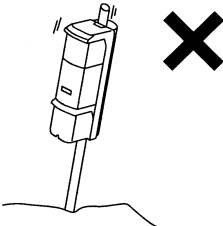

[7] Ensure that the mounting distance between the Transmitter and the Receiver (maximum detection range) is within the rating.

35-350ft. (10-100m):
 AX-350DH MK III
 AX-350DH TS
 AX-350DH BT

65-650ft. (20-200m):
 AX-650DH MK III

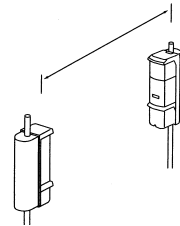

2. PARTS IDENTIFICATION

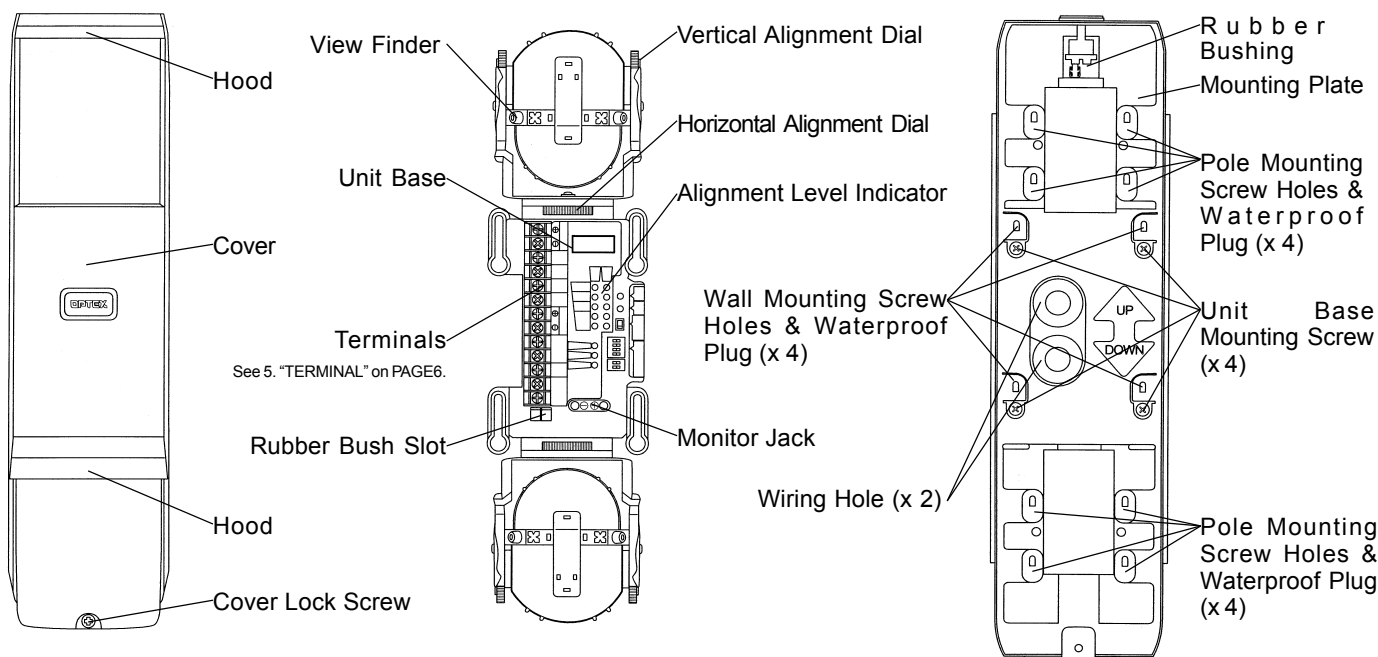

Switch Section Transmitter

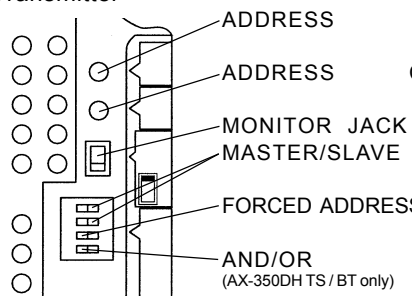

- CLEAR:** Resets the registered address to the factory settings (see 14. "TROUBLESHOOTING" on Page15).
- CHECK:** Indicates the registered address by the flickering of the six indicator LEDs for about 10 seconds (see 14. "TROUBLESHOOTING" on Page15).
- MONITOR JACK switch:** Switches between high and low the level of infrared beam reception output to the monitor jack.
- MASTER/SLAVE switch:** Use this switch for multiple beam installation (see 7-2. "Master/slave selector switch setting" on Page8). When more than one detector with the same address is on the alarm line, switches one of them.
- FORCED ADDRESS switch:** to prevent malfunction caused by cross talk (see 14. "TROUBLESHOOTING" on Page15).
- AND/OR switch:** units and to the OR mode for detection of interruption for either unit (see 7-3. "AND/OR selector switch setting" on Page8).

Receiver

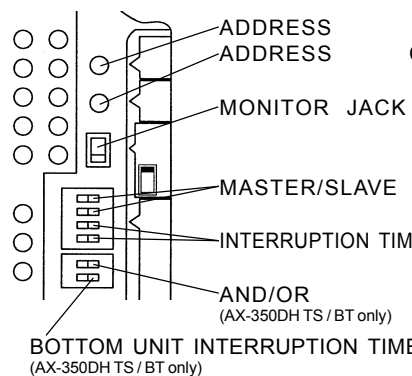

- CLEAR:** Clears the registered address (see 14. "TROUBLESHOOTING" on Page15).
- CHECK:** Indicates the registered address by the flickering of the six indicator LEDs for about 10 seconds (see 14. "TROUBLESHOOTING" on Page15).
- MONITOR JACK switch:** Switches between high and low the level of infrared beam reception output to the monitor jack.
- MASTER/SLAVE switch:** Use this switch for multi-level installation (see 7-2. "Master/slave selector switch setting" on Page8).
- INTERRUPTION TIME switch:** Switches the interruption time between the four settings (see 8. "BEAM INTERRUPTION TIME ADJUSTMENT" on Page11).
- AND/OR switch:** This switches the detection time for the top unit when AX-350DH TS / BT in the OR mode. Switch to the AND mode for detection of simultaneous interruption for the top and the bottom units and to the OR mode for detection of interruption for either unit (see 7-3. "AND/OR selector switch setting" on Page8).
- BOTTOM UNIT INTERRUPTION TIME switch:** Turning the switch to ON in the OR mode fixes the interruption time for the bottom unit to one second (see 8. "BEAM INTERRUPTION TIME ADJUSTMENT" on Page11).

3. NOTES ON INSTALLATION

[1] Detection range and installation height

distances between the Receiver and the Transmitter are listed below:

35-350ft. (10-100m) : AX-350DH MK III, AX-350DH TS, AX-350DH BT
 65-650ft. (20-200m) : AX-650DH MK III

Normally, the installation height should be 0.7 – 1.0m. When OR mode is used, the installation height of lower beam should be 15cm from the ground.

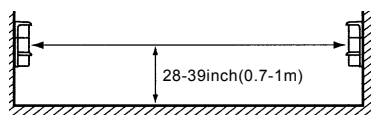

[2] Alignment angle

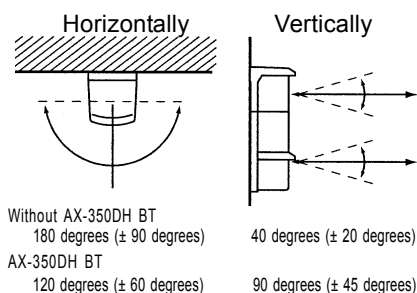

Note

For best performance, avoid aligning detectors at 45 degree angles except AX-350DH BT.

[3] Pole mounting

- Pole size should be diameter 1.9inch(48mm).
- The length of the wiring cable out of the pole should be within 23.5 inch(60cm).

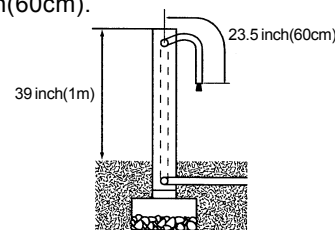

4. INSTALLATION METHOD

When using the back cover BC-1 (optional), see 12. "BACK COVER BC-1" on Page13

4-1. Wall mounting

[1] Removing the cover

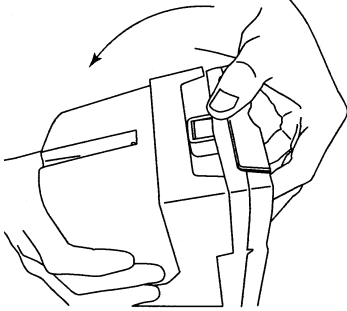

Loosen the cover lock screw and remove the cover.

Note

When removing the cover, do not put your finger on the hood, which may cause damage.

[2] Removing the unit base

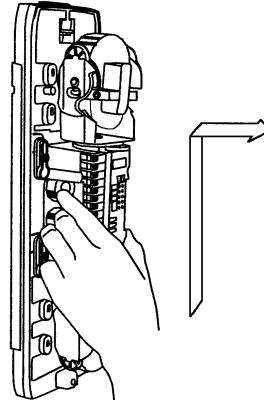

Loosen the four unit base mounting screws and remove the unit base by sliding it upward. The screws do not need to be removed.

[3] Preparing the wiring grommet

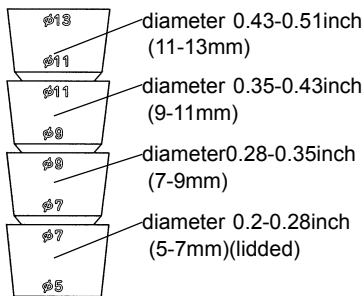

Cut the wiring grommet required according to the wire diameter. Use the lidded grommet for the wiring hole not to be used.

[4] Threading the wire

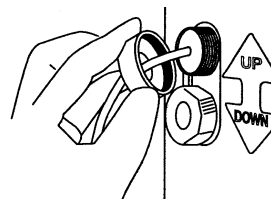

Remove the cap from the wiring hole and pull the wire through the hole. Then thread the wiring grommet down to about 3.9inch(10cm) from the end of the wire, apply the wiring grommet to the indentation at the wiring hole and securely tighten the cap.

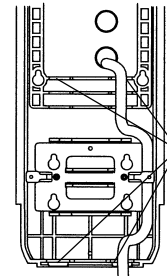

Knockouts

When wiring from the under surface, break the knockouts on the rear of the chassis.

[5] Securing the mounting plate

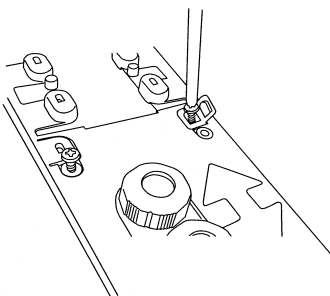

Remove the four waterproof plugs on the wall mounting screw holes and mount the plate with the self-tapping screws provided. Then securely attach the waterproof plugs.

[6] Mounting the unit base

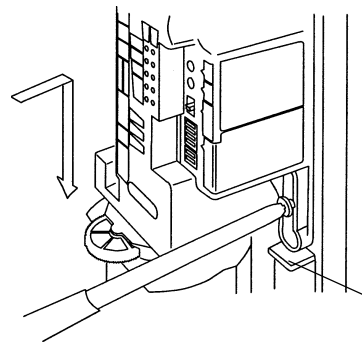

Secure the unit base in the reverse order of removing. Make sure that the unit base touches the stopper.

Stopper

[7] Connecting the terminals and aligning beams

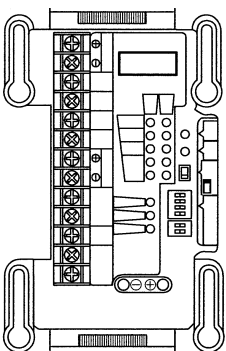

See 5. "TERMINAL CONNECTIONS" on Page6 to make connections to the terminals and refer to 7. "OPTICAL ALIGNMENT" on Page8 to make alignment for the maximum level of light reception.

[8] Checking the operations and attaching the cover

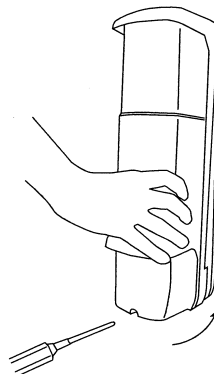

See 10. "WALK TEST" on Page12 to check the installation, put on the hook at the top of the cover to attach the cover and tighten the cover lock screw.

4-2. Pole mounting

[1] Removing the cover

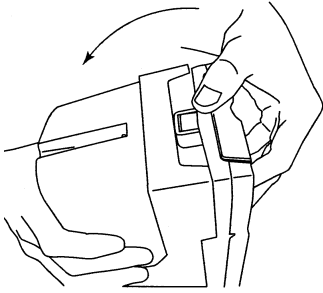

Loosen the cover lock screw and remove the cover.

Note

When removing the cover, do not put your finger on the hood, which may cause damage.

[2] Removing the unit base

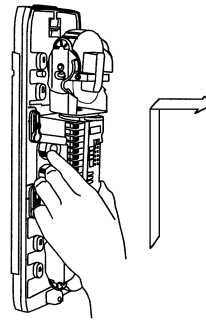

Loosen the four unit base mounting screws and remove the unit base by sliding it upward. The screws do not need to be removed.

[3] Preparing the wiring grommet

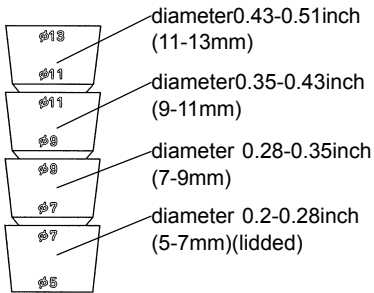

Cut the wiring grommet required according to the wire diameter. Use the lidded grommet for the wiring hole not to be used.

[4] Preparing the U-shaped brackets

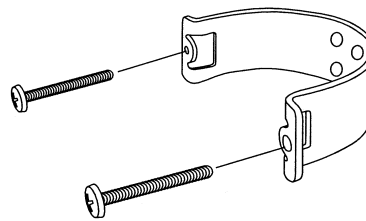

Attach the screws provided to the U-shaped brackets.

[5] Threading the wire

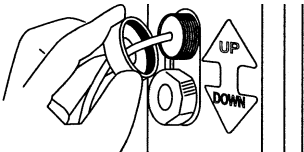

Remove the cap from the wiring hole and pull the wire through the hole. Then thread the wiring grommet down to about 3.9 inch (10cm) from the end of the wire, apply the wiring grommet to the indentation at the wiring hole and securely tighten the cap.

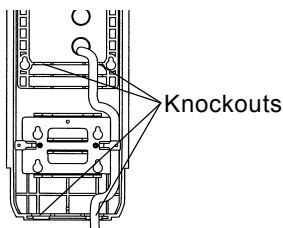

When wiring from the under surface, break the knockouts on the rear of the chassis.

[6] Securing the mounting plate

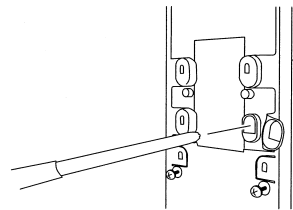

Remove the waterproof plugs from the pole mounting screw holes and screw the mounting plate onto the U-shaped brackets. Then securely attach the waterproof plugs.

*Two-unit installation (back to back)

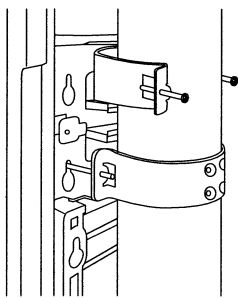

After mounting one of the units on the pole, place the U-shaped bracket in the gap. Mount the screws and secure the mounting plate.

[7] Mounting the unit base

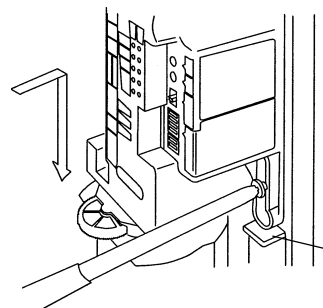

Secure the unit base in the reverse order of removing. Make sure that the unit base touches the stopper

Stopper

[8] Connecting the terminals and optical alignment

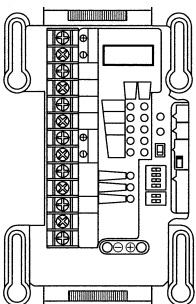

See 5. "TERMINAL CONNECTIONS" on Page 6 to make connections to the terminals and refer to 7. "OPTICAL ALIGNMENT" on Page 8 to make alignment for the maximum level of light reception.

[9] Confirmation of action and attaching the cover



See 10. "WALK TEST" on Page 12 to check the installation, put on the hook at the top of the cover to attach the cover and tighten the cover lock screw.

5. TERMINAL CONNECTIONS



WARNING

Do not exceed the voltage or current rating specified for any of the terminals during installation, doing so may cause fire or damage to the devices.



5-1.AX-350DH MK III, AX-650DH MK III

<Transmitter>

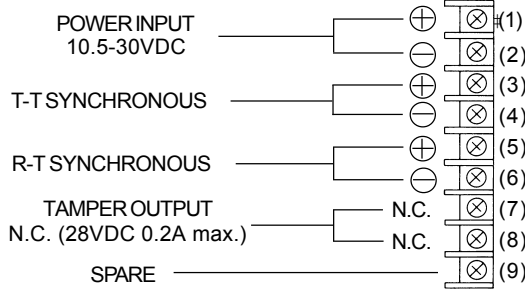

<Receiver>

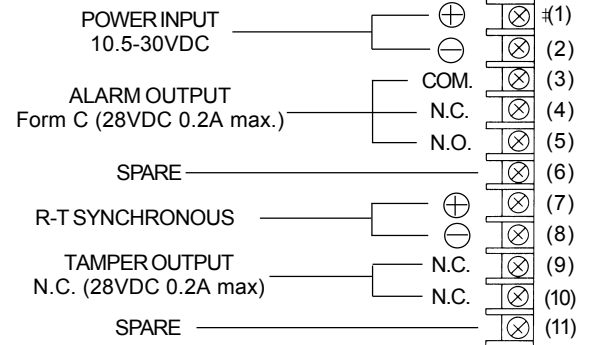

5-2.AX-350DH TS

<Transmitter>

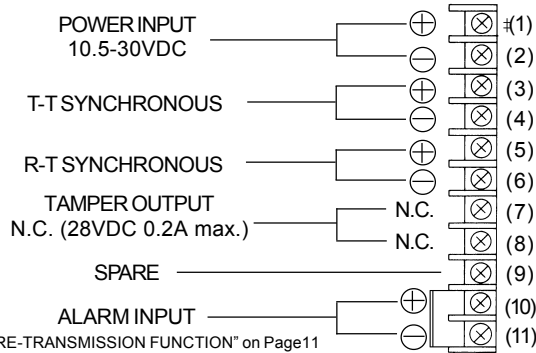

*See 9. "RE-TRANSMISSION FUNCTION" on Page11

<Receiver>

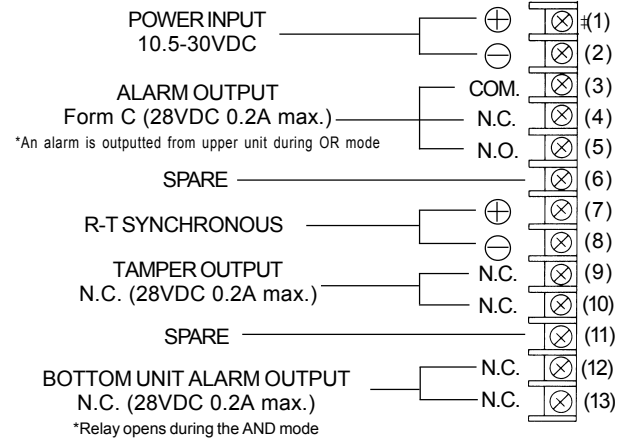

*An alarm is outputted from upper unit during OR mode

*Relay opens during the AND mode

5-3.AX-350DH BT

<Transmitter>

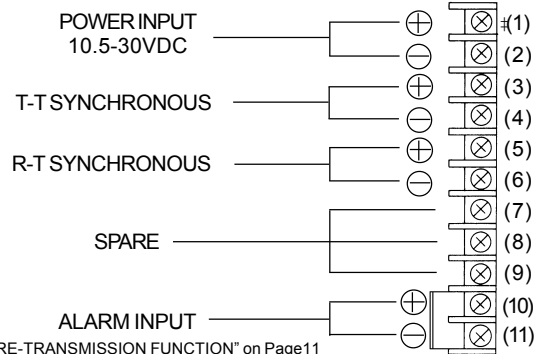

*See 9. "RE-TRANSMISSION FUNCTION" on Page11

<Receiver>

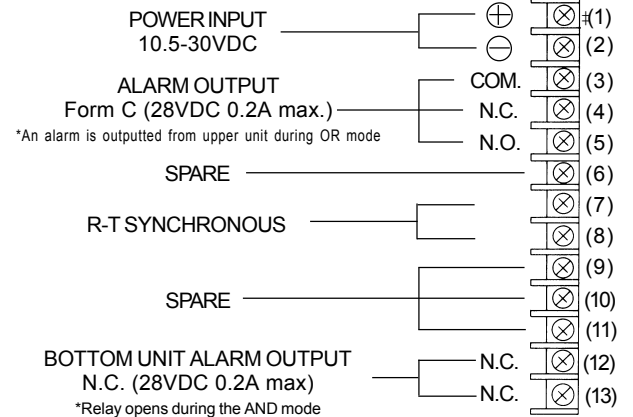

*An alarm is outputted from upper unit during OR mode

*Relay opens during the AND mode

6. WIRING

6-1. Wiring example

1-set installation

Connect the power supply in parallel.

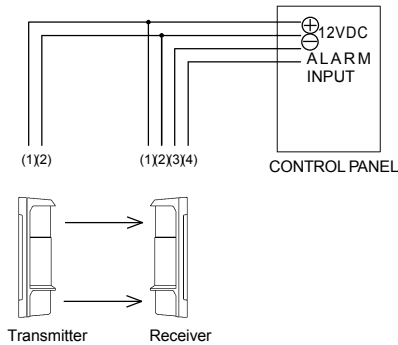

Multi-level installation

Connect the power supply in parallel. Connect the units serially for a normally closed alarm output and in parallel for a normally open output (the figure below shows an example for a normally closed alarm output). Provide the Transmitter/Receiver synchronization wiring and refer to 7-2. "Master/slave selector switch setting" on Page 8 to make the switch setting.

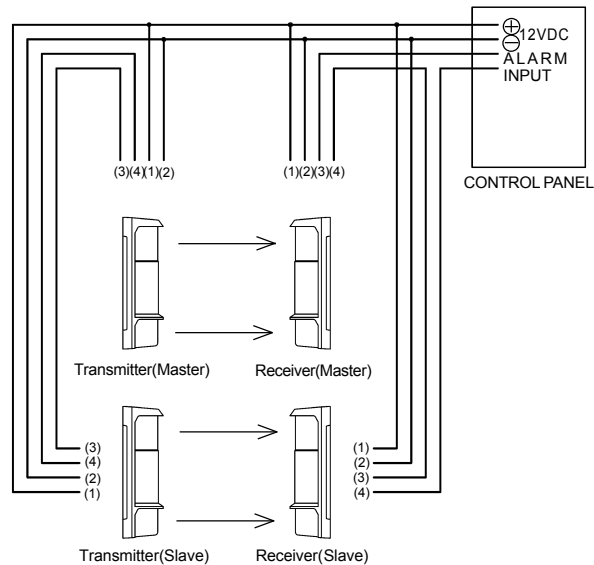

Note Be sure to make T-T synchronous wiring.

Installation of 2 or more sets

Connect the power supply in parallel. Connect the units serially for a normally closed alarm output and in parallel for a normally open output (the figure below shows an example for a normally closed alarm output). For linear alarm, provide the Transmitter/Receiver synchronization wiring.

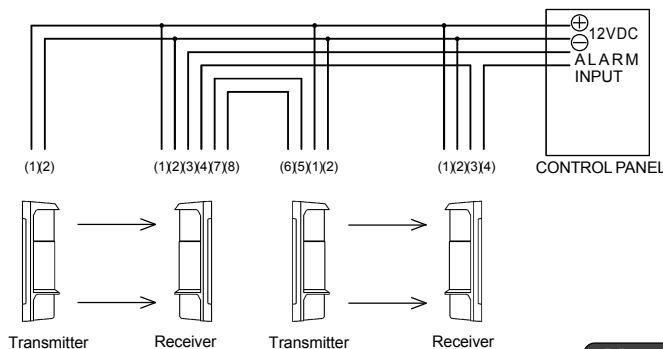

Note Be sure to make R-T synchronous wiring.

6-2. Wiring distance between power supply and detector

-Ensure that the wiring distance from the power supply is within the range shown in the table on the right.

-When using two or more units on one wire, the maximum length is obtained by dividing the wire length listed below by the number of units used.

Model	AX-350DH MKIII AX-650DH MKIII		AX-350DH TS AX-350DH BT	
	12VDC	24VDC	12VDC	24VDC
AWG22 (0.33mm ²)	420' (130m)	3600' (1100m)	360' (110m)	3100' (950m)
AWG20 (0.52mm ²)	650' (200m)	5500' (1700m)	550' (170m)	4500' (1400m)
AWG18 (0.83mm ²)	980' (300m)	8800' (2700m)	880' (270m)	7200' (2200m)
AWG16 (1.31mm ²)	1470' (450m)	12400' (3800m)	1240' (380m)	10000' (3200m)

7. OPTICAL ALIGNMENT

7-1. Aligning the optical axis

·Optical alignment is an important feature for maximizing the reliability of the product. Follow the instructions given in 7-2 to 7-5 in this chapter and make adjustment in such a way that the maximum voltage of the monitor jack is confirmed with the level indicator.

·Be sure to start optical alignment with the top beam .
The level indicator of the Transmitter may not work if the beam at the top level is not aligned.

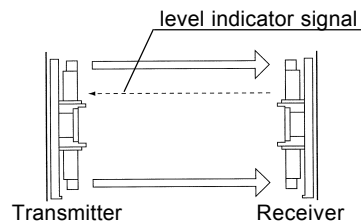

·In order to obtain the optical alignment accurately, apply the supplied optical reduction plate on the both upper and lower beams of one of the transmitter or receiver. Use the optical reduction plate according to installation distance. Remove the plate after the optical alignment is completed.

AX-350DH MKⅢ, AX-350DH TS, AX-350DH BT			
Installation distance	35 - 135' (10 - 40m)	135 - 350' (40 - 100m)	
Optical Reduction Plate	for short distance	not supplied	
AX-650DH MKⅢ			
Installation distance	70 - 165' (20 - 50m)	165 - 350' (50 - 100m)	350 - 650' (100 - 200m)
Optical Reduction Plate	for short distance	for middle distance	not supplied

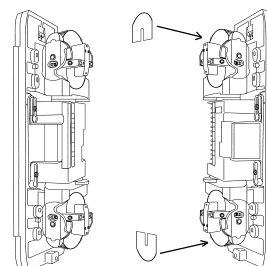

7-2. Master/slave selector switch setting

The master/slave selector switch is provided for preventing cross talk between infrared beams for multi-level alarm. From the top level, set the switches of both the Transmitter and the Receiver to Master -> Slave 1 -> Slave 2 -> Slave 3.

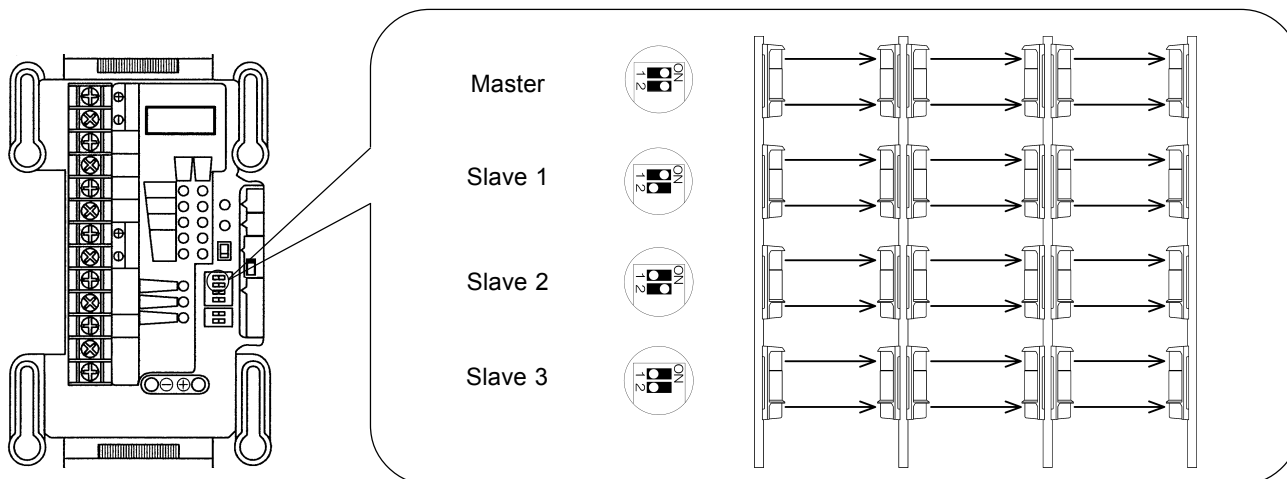

Note Be sure to make T-T synchronous wiring.
Be sure to set the switch to Master for single-level installation.

7-3. AND/OR selector switch setting (AX-350DH TS and AX-350DH BT only)

Models AX-350DH TS and AX-350DH BT allow switching between top/button level AND and OR detection modes. Using the OR detection mode is effective for detecting smaller human objects such as ingress by crawling. Be informed, however, OR mode may cause an increase in false alarms due to flying debris or small animals, care should be taken to ensure that all factors are considered when selecting OR mode.

<Transmitter>

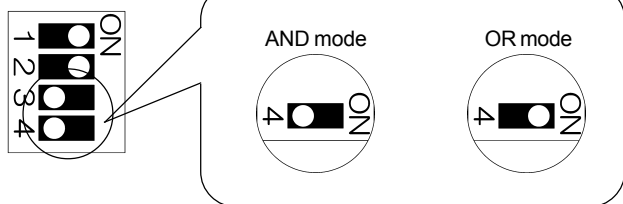

<Receiver>

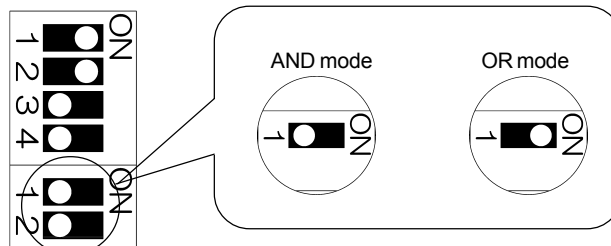

Note Make sure that the covers of both the Transmitter and the Receiver are open (the rubber bushings are not inserted for AX-350DH BT) when setting the switches.

7-3. Rough alignment by viewfinder

While looking through the viewfinder on the left or right of the mirror, turn the dial to make alignment in such a way that the other detector is at the center of the sights.

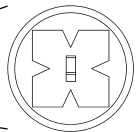
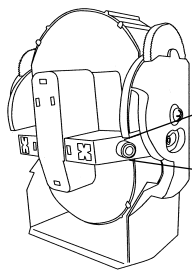

OK

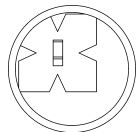

NG



Vertical Alignment Dial

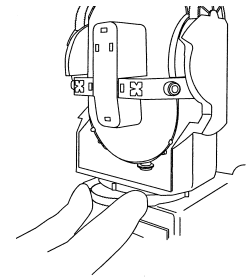

Horizontal Alignment Dial

Note

Be sure to adjust both the upper and lower mirrors.
Level indicator alignment is needed after the optical alignment is completed through viewfinder.

7-4. Adjustment with level indicator

[1] Checking of illumination of the indicator

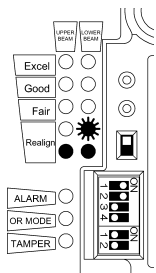

After the rough alignment using the viewfinder, make sure that one or more level indicator LEDs are illuminated or flickering for both the top and the bottom levels. If not, make adjustment again with the viewfinder.

[2] Adjustment in the rough alignment mode

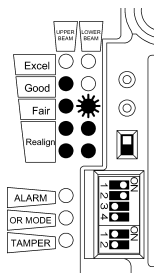

- Continuously ON
- Fast flicker
- Slow flicker

Make optical alignment until the level indicator LED at the "Good" position is illuminated. At this time, the level indicator LEDs at the lower positions remain illuminated. This condition is called the rough alignment mode.

In the rough alignment mode, each LED of the level indicator switches from the flickering to the continuously ON state as the level of light reception becomes higher.

Note

Be sure to start rough alignment with the upper mirror. Otherwise the level indicator of the Transmitter may not work.

[3] Switching to the fine adjustment mode

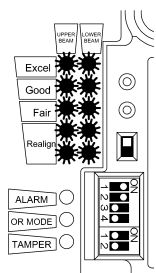

Once the level indicator LED at the "Excel" position is illuminated, all of the LEDs start flickering fast together, which indicates that the mode is switched to the fine adjustment mode. The level indicator LEDs at the lower positions do not remain illuminated in the fine adjustment mode.

Note

Depending on the accuracy of the rough alignment by viewfinder, the beam adjustment may be started from fine adjustment mode without rough adjustment mode.
It may not change to fine adjustment mode when the detector is used with maximum distance.

[4] Adjustment in the fine adjustment mode

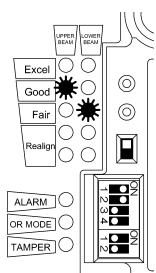

When the mode is switched to the fine adjustment mode, the level indicator LEDs start flickering and the indication point falls. How far the indication point goes down depends on the situation. Finding the peak position in this condition allows fine-tuning. When the level of the "Excel" level indicator LED exceeds the flickering level in the fine adjustment mode, all of the LEDs start flickering together again and the indication point falls automatically. Repeat this until the alignment peaks.

Note

In the fine adjustment mode, the indication point may not reach the "Excel" position. This indicates fine adjustment condition above the "Excel" position, which means that it causes no problem in operation.

7-5. Fine adjustment with monitor jack

Level of received light can be checked with voltmeter same as level indicator performs.

[1] Preparing the voltmeter

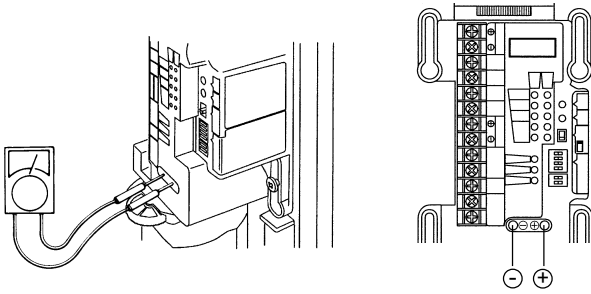

After the rough alignment using the viewfinder, make adjustment with the monitor jack for more accurate optical alignment. Set the voltmeter range to 5 to 10 VDC and connect the voltmeter probes \oplus and \ominus to \oplus and \ominus of the monitor jack respectively.

[2] Check the alignment level with volt meter

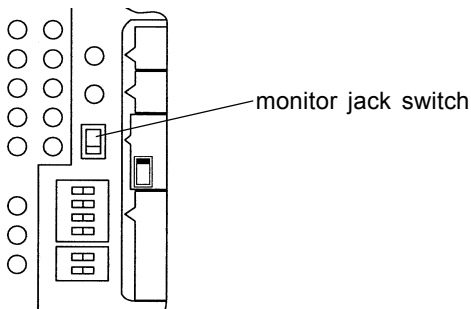

Check the alignment level with volt meter to ensure that proper alignment has been achieved. Switch the monitor jack switch to make sure that the voltage from both upper and lower beam is over 0.3V. Readjustment through viewfinder is required in case of the voltage is under 0.3V.

[3] Peak Find Adjustment

Make the optical alignment to reach its peak after the alignment through viewfinder is completed.

First of all, the monitor jack level has to be over 2.9V (AX-650DHMK III requires over 2.2V) when the optical alignment is completed. This is equivalent to the rough adjustment mode by the level indicator.

Note Be sure to start rough alignment with the upper mirror. Otherwise the level indicator of the Transmitter may not work.

The condition of the monitor jack being outputted over 3.4V is called "fine adjustment mode".

Furthermore, if the optical alignment is adjusted continuously and a monitor jack output achieves to 4.8V, the output value of a monitor jack will fall automatically.

In order to obtain the finest adjustment, this operation executes repeatedly.

In fine adjustment mode, the monitor jack output may not achieve 4.6V but there is no problem using the detector with this condition because the beam is in the state more than the superior position in rough adjustment mode when the optical adjustment mode switches to fine adjustment mode.

Relation between monitor jack output and beam achievement level

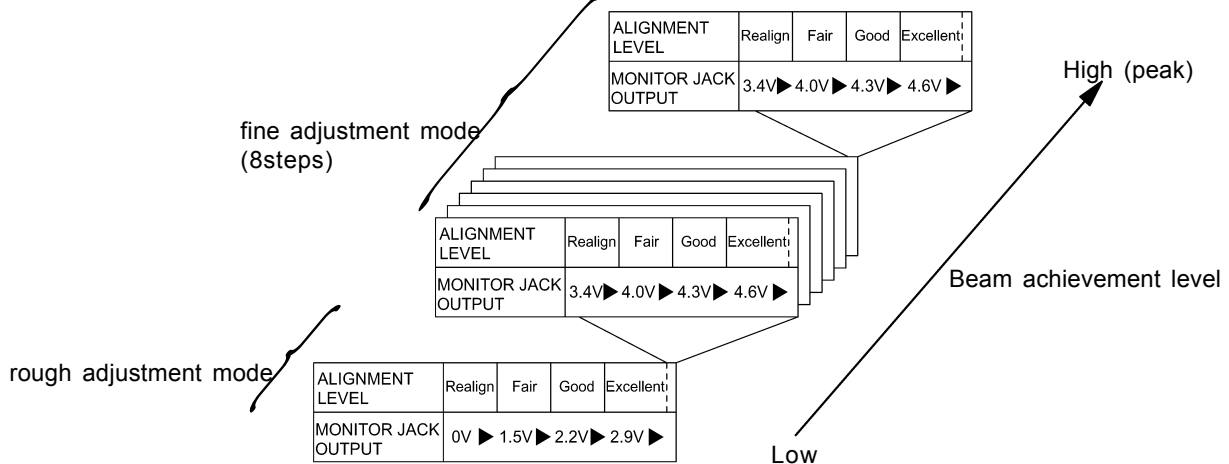

Note Depending on the accuracy of the rough alignment by viewfinder, the beam adjustment may be started from fine adjustment mode without rough adjustment mode. It may not change to fine adjustment mode when the detector is used with maximum distance.

8. BEAM INTERRUPTION TIME ADJUSTMENT

This adjustment function allows you to match the sensitivity of the unit to its surroundings. Adjusting the interruption time determines the speed of objects detected by the detector.

- When any large flying object to be disregarded such as a bird or a newspaper can occasionally interrupt the beam, set an appropriately long interruption time.
- Be sure to check the operation after adjusting the interruption time.

Set the interruption time adjustment switches of the Receiver according to the speed of the human object to detect.

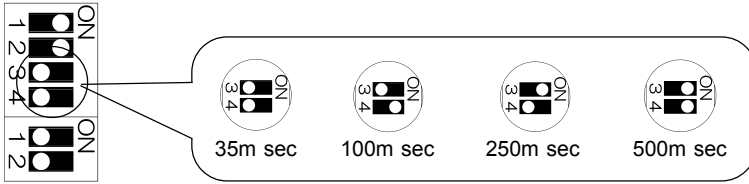

Beam interruption period

AND detection mode : time which both upper and lower beams are interrupted
OR detection mode : time which either upper or lower beam is interrupted

Bottom level interruption time adjustment (AX-350DH TS / BT only)

When the top/bottom level OR alarm is set, the interruption time for the bottom level can be set to 1 second. When the switch is turned OFF, the interruption time is set to the same as that of the top level.

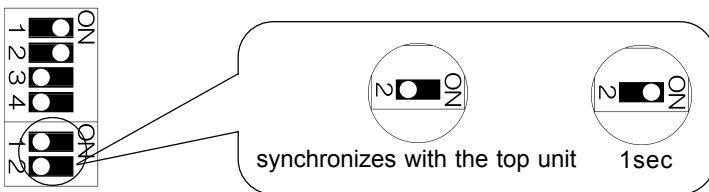

9. RE-TRANSMISSION FUNCTION (AX-350DH TS, AX-350DH BT only)

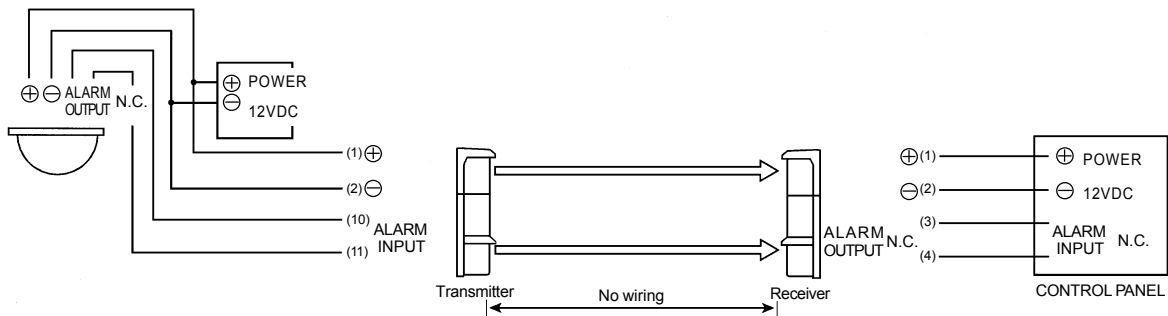

<Connection method>

- [1] Remove the jumper (U-shaped connector) between the alarm input terminals of the Transmitter.

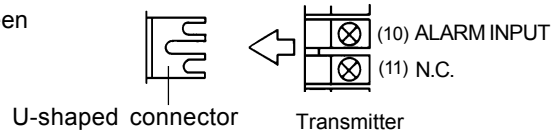

- [2] Connect the alarm output (normally closed) of other detector to the external alarm input terminal of the Transmitter (it cannot be connected to a sensor with a normally open alarm output).

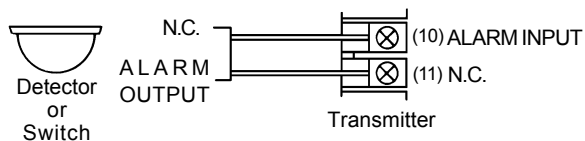

Note

Be sure to connect the jumper (U-shaped connector) when not using the alarm input terminal. If the jumper is removed, the transmission of the beam is stopped, which causes the Receiver to output an alarm signal.

10. WALK TEST

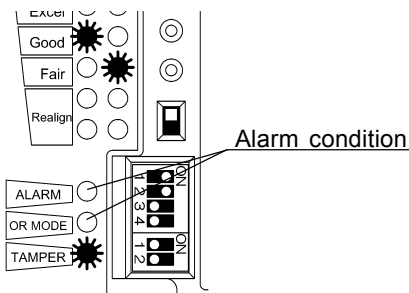

Make sure that the "Alarm condition" LED is OFF. If it is illuminated even when the beams are not blocked, make optical alignment again.

*AX-350DH TS and AX-350DH BT has alarm output for lower detector.

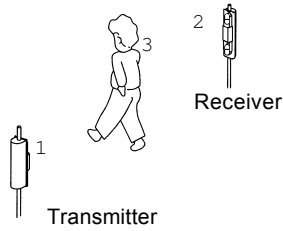

Be sure to conduct a walk test (to block the infrared beam) at the following three points:

1. In front of the Transmitter
2. In front of the Receiver
3. At the middle point between the Transmitter and the Receiver

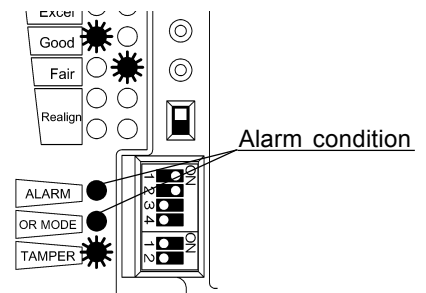

If the "Alarm condition" LED is turned ON when the beam is blocked, installation is complete.

*AX-350DH TS and AX-350DH BT has alarm output for lower detector.

Note If the "Alarm condition" LED is not illuminated even if the beam is blocked, follow the instructions in "14. TROUBLESHOOTING" on Page15 and solve any problem.

11. HEATER UNIT HU-2 (Option)

- Feature -

The heat release effect makes the unit less prone to frost.

11-1. Mounting method

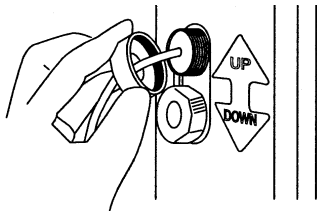

Remove the cap from the wiring hole and pull the wire through the hole. Then thread the wiring packing down to about 6 inch from the end of the wire and securely tighten the cap.

Note Power supply of 24 VAC/DC is required to use the heater unit. Use separate wiring from that of the detector because the current draw of the heater unit can be as large as 430 mA each.

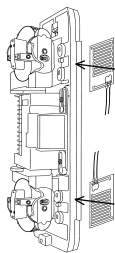

Remove the release paper on the rear of the heater unit and paste the unit in line with the guide of the mounting plate for both the top and the bottom levels.

Note Be sure to mount the heater unit for both the top and the bottom levels. Otherwise the effectiveness may be reduced.

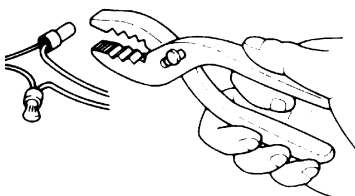

When connecting the heater unit leads to the wiring, solder the wires or use the connectors provided with the heater unit and securely connect the wires one by one. Put the connector on the wires and crimp with pliers, etc.

11-2. Wiring distance between power supply and detector

- Ensure that the wiring distance from the power supply is within the range shown in the table on the right.
- When using two or more units on one wire, the maximum length is obtained by dividing the wire length listed below by the number of units used.

WIRE SIZE	WIRING DISTANCE
AWG18 (0.83mm ²)	500'(150m)
AWG16 (1.31mm ²)	850'(250m)
AWG14 (2.09mm ²)	1300'(400m)

12. BACK COVER BC-1 (Option)

- Feature -

Hides the pole and wiring on the rear of the detector for tidier appearance.

[1]

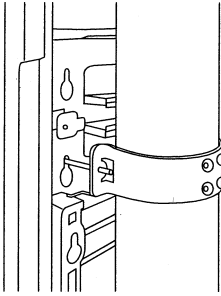

See 4. "INSTALLATION METHOD" to mount the detector on the pole.

[2]

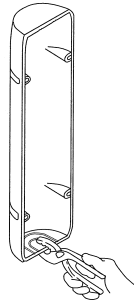

Break the knockout of the back cover with pliers, etc.

[3]

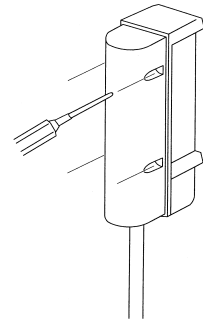

Screw the back cover onto the detector.

13.DIMENSIONS

• < AX-350DH MK#V, AX-650DH MK#V, AX-350DH TS >

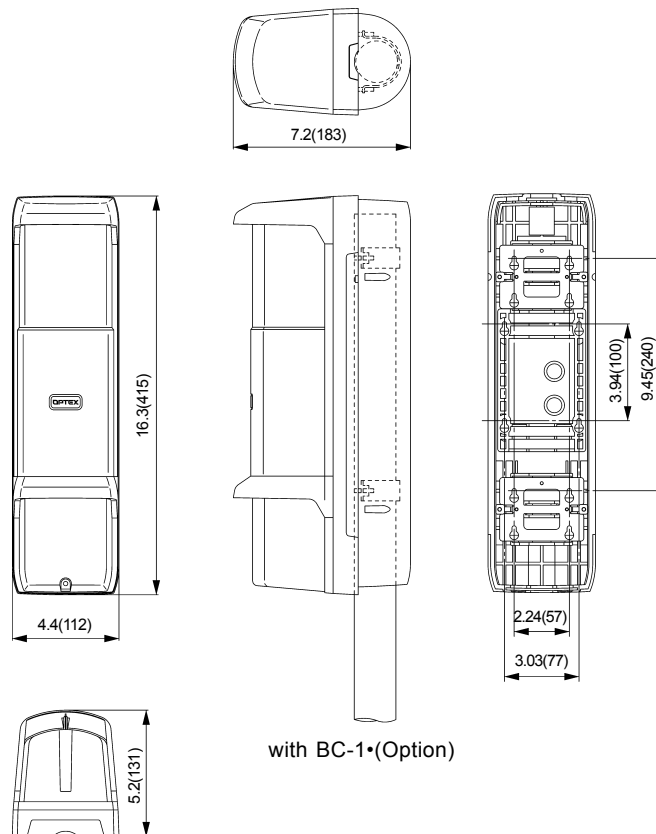

Dimensions:inch (mm)

< AX-350DH BT >

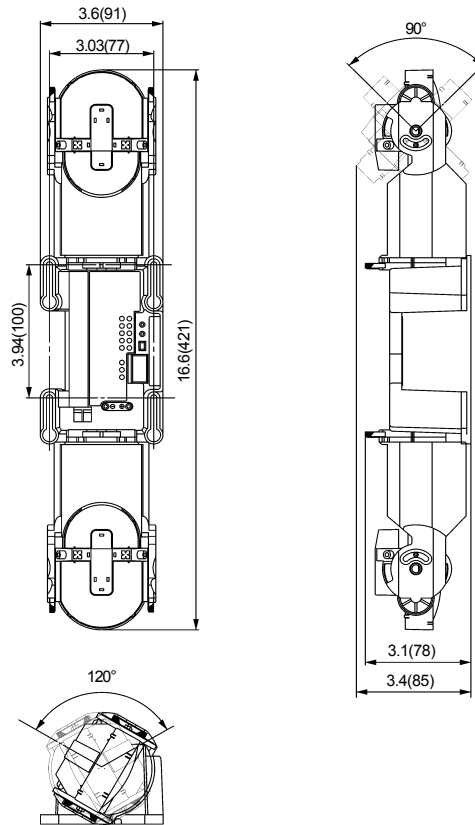

Dimensions:inch (mm)

< HU-2 >

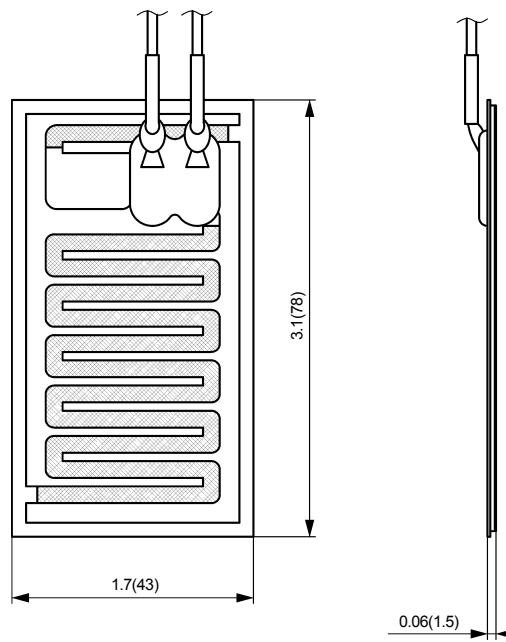

Dimensions:inch (mm)

14. TROUBLESHOOTING

Problem	Possible Cause	Corrective Action
LEDs on the Transmitter are not illuminated.	Inappropriate power voltage	Check the voltage and make sure that it is between 10.5 and 30 VDC.
	Disconnection in power line	Check the wiring.
	Inappropriate wiring distance or wire diameter	See 6-2 "Wiring distance between power supply and detector" on Page7 and check the wiring distance.
LEDs on the Receiver are not illuminated	Inappropriate power voltage	Check the voltage and make sure that it is between 10.5 and 30 VDC.
	Inappropriate wiring distance or wire diameter	See 6-2 "Wiring distance between power supply and detector" on Page7 and check the wiring distance.
"Alarm condition" LED is not illuminated even if the beam is blocked in front of the Receiver.	Infrared beam reflected on the floor or wall of the building to enter the Receiver	See 7. "OPTICAL ALIGNMENT" on Page8 to make realignment. If the problem persists, remove any object that reflects the beam or change the location of installation.
	Top and bottom beams not blocked at the same time.	Ensure that the top and the bottom beams are blocked at the same time.
	T-T synchronization or R-T synchronization wiring not in place	See 5. "TERMINAL" on Page6 to make synchronization wiring, press the ADDRESS CLEAR switch and close the cover.
	Detector of the same address installed	Press the ADDRESS CHECK switch and check the indicator illumination to see if there is any detector with the same address. If there is, change the FORCED ADDRESS switch setting of one of the Transmitters, press the ADDRESS CLEAR switch and close the cover.
Blocking the beam in front of the Receiver illuminates the "Alarm condition" LED but does not activate the alarm.	Signal line short-circuited	Check the wiring.
	Alarm contact welded	Repair is required. Contact the distributor or us.
"Alarm condition" LED of the Receiver does not go out.	Optical axis of Transmitter and Receiver not aligned	See 7. "OPTICAL ALIGNMENT" on Page8 and make realignment.
	Object blocking the beam between Transmitter and Receiver	Remove the object or move the unit to a place without any object that may block the beam.
	The addresses of Transmitter and Receiver not matched	Press the ADDRESS CLEAR switch and put the cover on.
Frost, snow or heavy rain causes false alarm.	Optical alignment not optimized	See 7. "OPTICAL ALIGNMENT" on Page8 and make realignment.
	MASTER/SLAVE switch set to SLAVE in standalone use	See 7-2. "Master/slave selector switch setting" on Page8 and switch to MASTER.
Alarm is activated even if the light is not blocked.	MASTER/SLAVE switches of the top and the bottom units both set to MASTER in multi-level installation	See 7-2. "Master/slave selector switch setting" on Page8 and correct the switch settings.
	Synchronization wiring incorrect	See 6-1. "Wiring example" on Page7 and provide the synchronization wiring correctly.
	Bird or flying debris blocking the beam between Transmitter and Receiver	See 8. "INTERRUPTION TIME ADJUSTMENT" on Page11 and set an appropriate interruption time.
	Vehicle or plant blocking the beam between Transmitter and Receiver	Remove any object blocking the beam.
	Surface of Transmitter/Receiver cover soiled	Clean the cover (wipe the cover with a soft cloth dampened with water or diluted neutral detergent).
	Inaccurate optical alignment	See 7. "OPTICAL ALIGNMENT" on Page8 and make realignment.
	Interruption time too short	See 8. "INTERRUPTION TIME ADJUSTMENT" on Page11 and set an appropriate interruption time.
	Inappropriate location of installation	Change the location.
Indicator LEDs of the Transmitter are not illuminated.	Inappropriate optical alignment for the upper mirror	See 7. "OPTICAL ALIGNMENT" on Page8 and make realignment.
AND/OR switching cannot be made.	Switching not made with the covers (rubber bushings for AX-350DH BT) of both Transmitter and Receiver removed.	Make switching with the covers (rubber bushings for AX-350DH BT) of both the Transmitter and the Receiver removed.

*If the problem persists after checking and taking the corrective action as above, contact the distributor or us.

15. SPECIFICATIONS

< AX-350DH MK III, AX-650DH MK III, AX-350DH TS, AX-350DH BT >

Name	PHOTOELECTRIC DETECTOR			
Model	AX-350DH MK III	AX-650DH MK III	AX-350DH TS	AX-350DH BT
Maximum detection range	35 - 350ft. (10 - 100m)	65 - 650ft. (20 - 200m)	35 - 350ft. (10 - 100m)	35 - 350ft. (10 - 100m)
Maximum arrival distance	3500ft.(1000m)	6500ft.(2000m)	3500ft.(1000m)	3500ft.(1000m)
Detection method	Infrared beam interruption detection			
Interruption time	Variable between 35, 100, 250 and 500 msec (four steps)			
Power voltage	10.5 - 30VDC			
Current draw (Transmitter + Receiver)	105mA max	110mA max	127mA max	
Alarm period	2 ± 1 sec (Normal)			
Alarm output	Form C Relay (28 VDC, 0.2 A max)			Bottom Unit : N.C. (28 VDC, 0.2 A max)
Tamper switch	N.C. ; open when cover is removed			
Operating temperature	-30°F - +131°F (-35°C - +55°C)			
Environment humidity	95% max			
Alignment angle	± 90 degrees horizontal ± 20 degrees vertical			±60 degrees horizontal ±45 degrees vertical
Location of installation	Indoor/outdoor; wall/pole mounting			Beam Tower
Mass (Transmitter + Receiver)	97oz (2750g)		99oz (2800g)	34oz (950g)
Accessories	U-shaped brackets (4), pole mounting screws (8), wall mounting screws (8), wiring grommet (4)			Mounting screws (8), rubber bushings (2)
Optional parts	Heater unit (HU-2), Back Cover(BC-1), Beam Tower			Beam Tower

< HU-2 (Option) >

Name	Heater unit
Model	HU-2
Power Input	24VAC/DC
Current draw	430 mA (max) per sheet
Maximum unit temperature	+131°F (+60°C)
Accessories	Rubber bushings (2), connectors (2), sealing material (1)

*The specifications may be modified without notice for improvement.

<Note>

This product is intended for detecting intruders and activating alarm and is not an antitheft device. Please be notified that we will not be held responsible for any damage caused in the unlikely event of theft.

NOTE

These units are designed to detect movement of an intruder and activate an alarm control panel. Being only part of a complete alarm system, we cannot accept responsibility for any damages or other consequences resulting from an intrusion. These products conform to the EMC Directive 89/336 EEC.



**OPTEX CO., LTD.
(JAPAN)**
(ISO 9001 Certified by LRQA)
(ISO 14001 Certified by JET)
5-8-12 Ogoto
Otsu, Shiga, 520-0101
Japan
Tel: +81-77-579-8670
Fax: +81-77-579-8190
URL <http://www.optex.co.jp/e>

**OPTEX INCORPORATED
(USA)**
1845W. 205th Street
Torrance, CA 90501-1510
U.S.A.
Tel: +1-310-533-1500
Fax: +1-310-533-5910
URL <http://www.optexamerica.com>

**OPTEX (EUROPE) LTD.
(UK)**
(ISO 9001 Certified by NQA)
Clivemont Road, Maidenhead,
Berkshire, SL6 7BU
UK
Tel: +44-1628-631000
Fax: +44-1628-636311
<http://www.optexeuropa.com>

**OPTEX SECURITY SAS
(FRANCE)**
7 allée du Crêt,
ZA des Monts d'Or
69890 La Tour de Salvagny
France
Tel: +33.4.78.19.67.57
Fax: +33.4.78.19.41.12
<http://www.optex-security.com>

**OPTEX KOREA., LTD.
(KOREA)**
1001 Sambu Renaissance-Tower 456,
Kongduck-Dong, Mapo-Gu, Seoul
Korea
Tel: +82-2-719-5971
Fax: +82-2-719-5973
<http://www.optexkorea.com>